

**Doppstadt**

**KIMO**

**TYPE 16 . TYPE 20**

MID SPEED SHREDDER LINE



**Best Solution. Smart Recycling.**

**doppstadt.com**



### **ROTOR**

The rotor consists of a solid forged shaft and has an outer diameter of 785 mm.



### **CUTTING KNIVES**

The knives are screwed into high knife holders and ensure a low level of friction as well as good intake behaviour.



### **MAINTENANCE DOOR**

The front maintenance door is opened by a hydraulic cylinder and ensures a large working space for carrying out service and maintenance work on the rotor knives and stator blade.



### **HYDRAULIC POWER PACK**

The hydraulic power pack on the KIMO Type 16 has an 11 kW drive. That of the Type 20 got 15 kW of power. The hydraulics are used to lift up the swing pusher, to open the front maintenance door and to lower the screen basket.

## **KIMO TYPE 20**

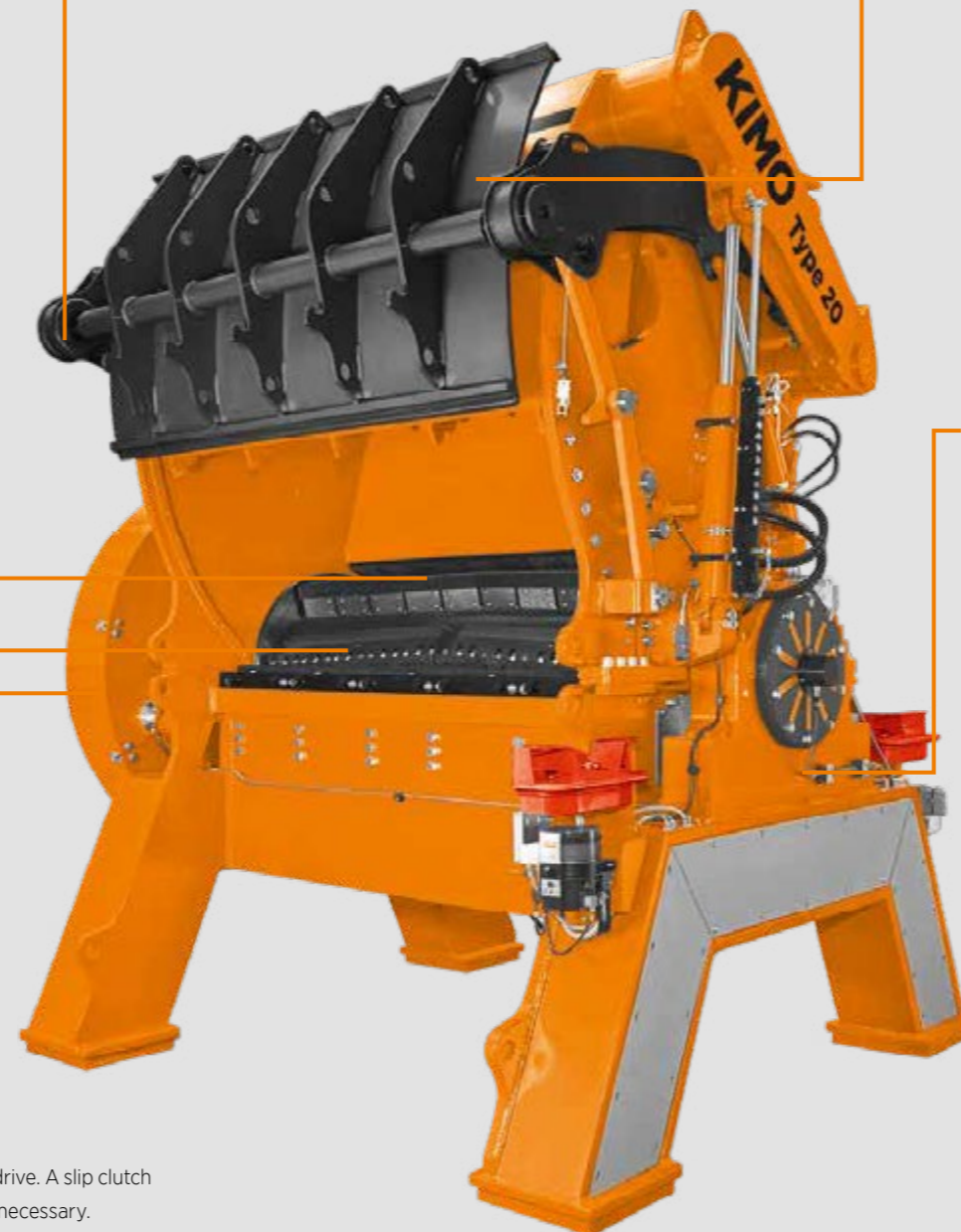

### **BASKET MAINTENANCE DOOR**

The screen basket is lowered by hydraulic cylinders to ease maintain such as changing the screen segments. For operation the screen basket is hydraulically lifted and firmly screwed onto the frame.



### **DRIVE UNIT**

The motor is positioned on a height-adjustable platform. To tension the V-belt the motor can be raised via a threaded steel rod. Thanks to this arrangement, both pulleys constantly remain in alignment.



### **BELT DRIVE**

The motor powers the large flywheel and rotor with a V-belt drive. A slip clutch disengages the rotor from the flywheel to protect the drive if necessary.



## **At a glance**

The production of RDF for the cement industry requires a high level of reliability and robustness without compromise. It calls for a machine that doesn't immediately come to a standstill when faced with larger, solid contaminants.

- Low running costs on account of the low energy consumption and costs for spare and wear parts
- High throughput thanks to the high knife holders
- Low vibrations
- Simple maintenance thanks to large access areas and easy tool replacement
- Consistently good shredding quality thanks to the adjustable, static knife blocks

# KIMO TYPE 16 AND TYPE 20

## The high-performance cutting mills.

The KIMO isn't fussy about its input. It is so robustly outfitted for the secondary shredding of any type of refuse-derived fuel that not even larger contaminants can slow it down.

The KIMO is available in two sizes. Its Type 16 and Type 20 models reliably meet all demands you could place on a mid-speed cutting shredder. With its rotor diameter of 785 mm, the KIMO is an unrivalled market leader. In combination with the large rotor pulley, this results in a very high moment of inertia, which helps to even out peaks in power demand caused by the heterogeneous input material. As a result, the drive can be scaled down to save on energy.

The material, which is continuously fed into the machine by a belt conveyor, is forced into the cutting area by the robust, polymer concrete-filled swing pusher. The rotor mounted knives cut the material against the stator blade and guides it towards the screen through which the finished product falls onto a belt conveyor. The KIMO is so heavily and robustly built that it does hardly vibrate at all. Thus, no anchors are needed to fix the machine in place.



### THIS IS DOPPSTADT

Doppstadt is one of the world's leading suppliers of innovative solutions in the field of environmental technology. The company specialises in the treatment and processing of reusable materials obtained from waste, biomass, earth, sand and gravel. Its portfolio includes easy-to-maintain, easy-to-use machines for the most complex

and challenging applications such as crushing, separating, sifting, mixing, splitting, wet processing and conveying. The company employs 700 people in locations all over the world to work on its machines, processes and solutions. The Group has an international network of dealers, with 42 partners in 45 countries. The

Doppstadt Group was founded in 1965 and has centres of expertise at Velbert (prototype development and production), Wülfrath (sales and service), Calbe (series production) and Wilsdruff (water based separation), in Germany.

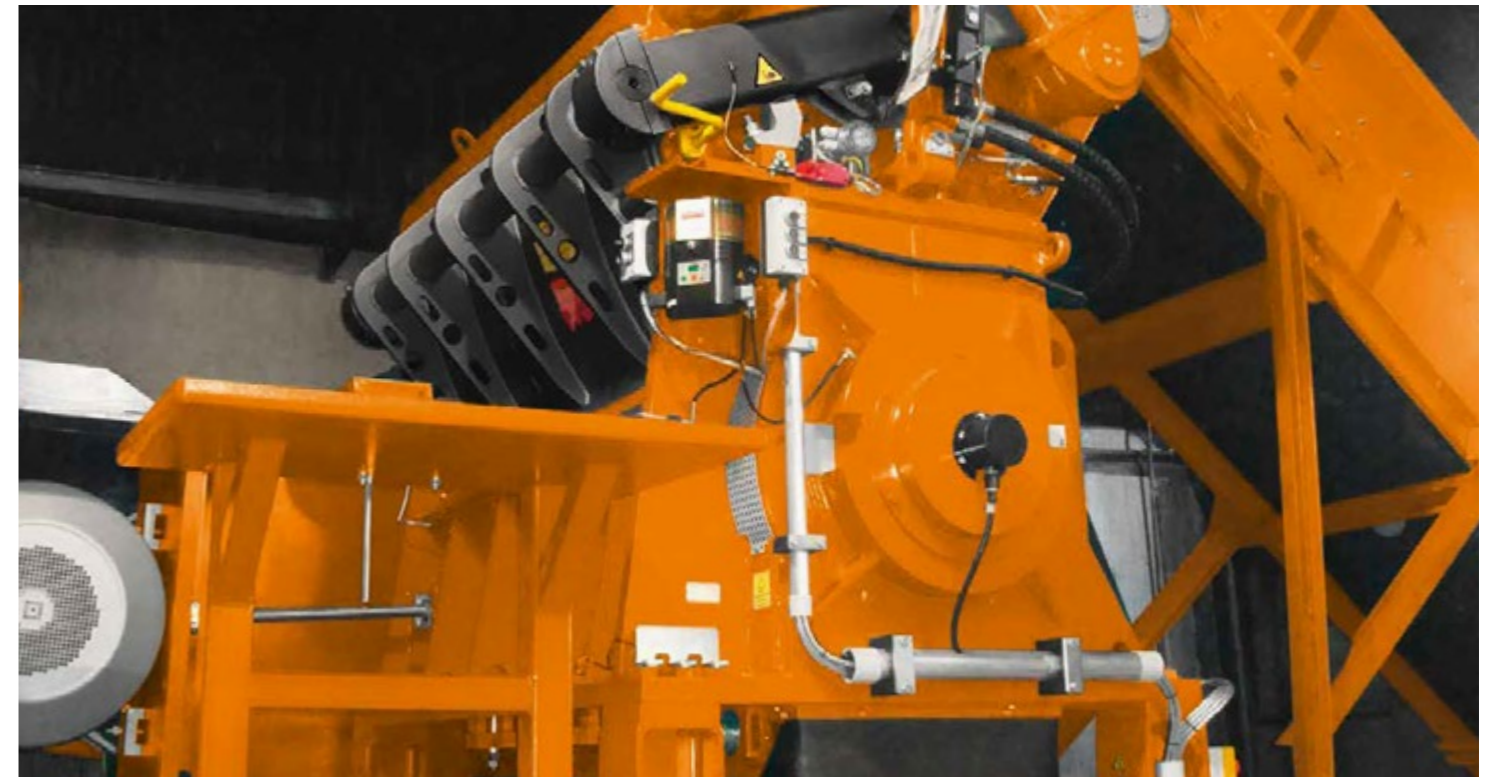

# KIMO TYPE 16 AND TYPE 20

## Economical, reliable secondary shredding

The KIMO Type 16 offers you a robust, efficient solution for a wide range of secondary shredding applications. The 1,600 mm long rotor of the Type 16 is powered by a 250 kW three-phase motor. The large momentum of inertia of rotor and flywheel accounts for the energy-efficient drive. For facilities with higher throughputs, the KIMO Type 20 is ready and waiting with a

2,000 mm long rotor and 315 kW drive. As far as screening area is concerned, its rotor geometry means that the KIMO Type 20 can more than keep up with conventional machines with rotor lengths of 3,000 mm and achieves similar throughputs. The KIMO shreds pre-sorted, high-calorific residual material. The finished product can then be used as refuse-derived fuel. The

KIMO is predominantly used for plastic foils and lightweight packaging, but also for shredder light fraction, carpets and pre-shredded tyres. The KIMO comes into its own where other shredders reach their limits. Even so for applications such as cable scrap, car radiators or electronic waste with electric motors of up to 1.5 kg.

### THE END PRODUCT

The KIMO performs different tasks depending on the input material. For refuse-derived fuels, it serves as a secondary shredder at the end of the treatment cycle for achieving a defined particle size distribution for good transportability and combustion properties. For electronic waste, car radiators, oil filters etc., it serves to break up and separate the material before sorting.



# TECHNICAL DETAILS

## KIMO

Type	Type 16	Type 20
Set-up	Stationary	Stationary
Total weight (kg)	23,500	26,000
Drive	Electric	Electric
Output (kW)	250	315
Rotor diameter (mm)	785	785
Feed width (mm)	1,630	2,020
Working width (mm)	1,600	2,000
Dimensions (L/W/H) (mm)	2,990 x 2,800 x 3,360	2,990 x 3,200 x 3,360
Hydraulic unit (kW)	11	15
Rows of rotor knives	5	5
Rows of stator knives	1	1
Number of rotor knives	40	50
Example: pre-shredded RDF with a planar input material of up to 300 mm and 35 mm screen baskets		
Throughput (t/h)	6 – 8	8 – 12
Rotational speed (rpm)	250	250

KIMO Type 16

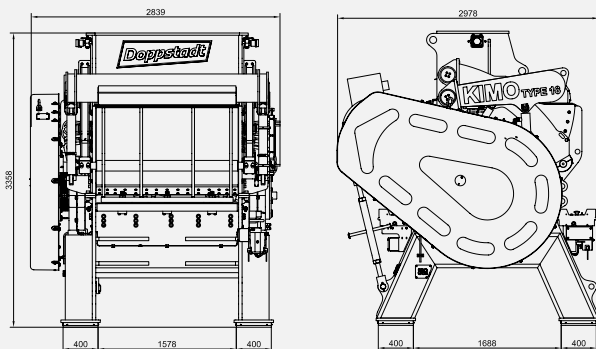

KIMO Type 20

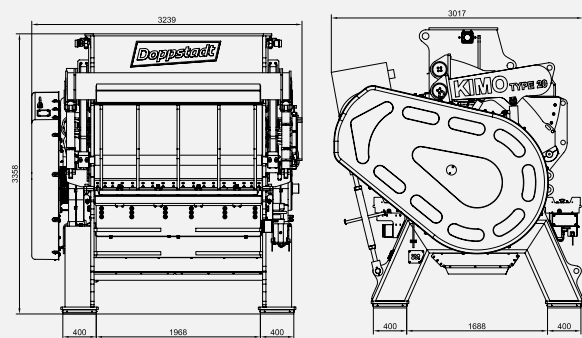

Werner Doppstadt  
 Umwelttechnik GmbH & Co. KG  
 Steinbrink 13, D-42555 Velbert

[doppstadt.com](http://doppstadt.com)

Telefon +49 2052 889-0  
[info@doppstadt.de](mailto:info@doppstadt.de)